

MULTIMEDIA FILTER

Hydrofil series



Be Assured Of Our Commitment

We provide high quality designs & products and offer ongoing technical support as well as on-site maintenance.

Competence

Our team of dedicated technical specialists is thoroughly trained to provide the highest standard of service.

Credibility

We are an established water treatment company, in operation since 2007. Our customers consist of some of the world's most recognizable brands, ranging from Pharmaceutical to Petrochemical conglomerates.

Standard Features

- **Vessels:** FRP
- **Internals:** Polypropylene Strainers
- **Media:** Anthracite or Activated Carbon, Fine Sand, Garnet, Gravel, Coarse gravel
- **Face piping:** PVC
- **Valve:** Automatic Valves
- **Controls:** Electrical Controller

Advantages

- Efficient designs & Simple Operation
- Standard Construction, Short delivery lead time
- Provides effective suspended solids filtration to 10 microns
- Contain multiple layers of various media for finer filtration
- Inlet/Outlet pressures gauges (Optional)
- Backwash flow control (Optional)
- Pressure relief valve for pressure fluctuations (Optional)
- Vent valve (Optional)
- Clear section backwash drain line for visual inspection (Optional)
- Stand alone tanks or modular skid mounted (pre-piped & pre-wired) (Optional)
- Air scour (Optional)

Purpose

- Reduce suspended solids (SS), turbidity, SDI, Dirt, Sand and sediment.
- Reduce chlorine, colour, odour and dissolved organic matter with Granular Activated Carbon.

Operating Parameters

- **Temperature:** 2°C-45°C (35.6°F-113°F)
- **Inlet Pressure:** 0.2-0.6MPa
- **Operating Pressure:** 0.3-0.6 MPa
- **Electrical:** 240 VAC, 1-Ph, 50Hz

Principle of Operation:

Feed water enters the vessel through control valve and is distributed across the media bed through a main header. Depending on the option selected by customer, the **Hydrofil** series filter can be tailor made as a multimedia filter or an activated carbon filter.

For Multimedia filter, Anthracite and graded sand will be used for the reduction of suspended solids, colour, from the feed water. For Activated Carbon filter, activated carbon in combination with graded sand will be used to reduce free chlorine, colour, odour and suspended solids from the feed water. The clean filtrate, depending on the type of vessel selected, will exit the filter either through the riser tube or the bottom distributor of the vessel.

Over time the filter will observe an increase in pressure drop across the media. A backwash step is required to flush out contaminant that is trapped within the media bed. During backwash, the flow is reversed and feed water enters the vessel either through the riser tube or bottom distributor. This is then followed by a forward rinse step to flush additional contaminant from the bottom of the media bed.

Features and Specifications

Model	Flow rate (m ³ /h)	Pipe (Inch)		Approx. Weight (Kg)		Approx. Dimension (m)			Controller Position	Vessel
		Main	Inlet/Outlet	Shipping	Loaded	W	L	H		
MMF/ACF										
-02-1	2	1	1	57	146	0.45	0.45	1.42	Top	
-04-1	4	1	1	135	318	0.56	0.56	1.77	Top	
-08-2	8	2	1	435	1851	1.11	0.56	1.77	Top	
-12-3	12	2.5	1	552	2676	1.67	0.56	1.77	Top	
-15-1	15	3	2	501	1209	1.06	1.38	2.20	Side	
-20-1	20	3	3	702	1702	1.20	1.65	2.20	Side	
-25-1	25	3	3	954	2264	1.35	1.80	2.20	Side	
-30-2	30	4	2	1001	2417	2.12	1.38	2.20	Side	
-30-1	30	3	3	1229	2903	1.50	1.95	2.20	Side	
-35-1	35	4	4	1229	2903	1.50	1.95	2.20	Side	
-40-2	40	4	3	1404	3403	2.40	1.65	2.20	Side	
-45-2	45	4	3	1907	4527	2.70	1.80	2.20	Side	
-50-2	50	4	3	1907	4527	2.70	1.80	2.20	Side	
-50-1	50	4	4	2162	5467	1.90	2.35	2.50	Side	

*- Apply the respective denotation when ordering. e.g. When ordering an ACF of 25 m³/hr, the denotation should be ACF-25-1.

Illustration for Single Vessel Configuration

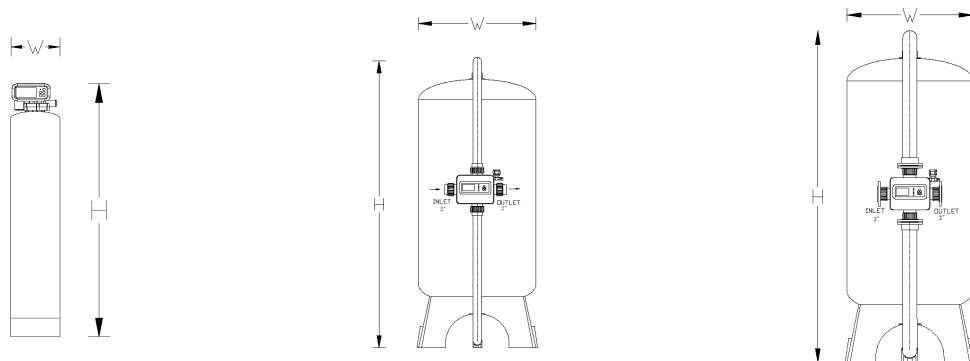

Top mounted controller
(Low Flow)

Side mounted controller
(Low Flow)

Side mounted controller
(High Flow)

Notes:

- Pressure drop of 10 psig is expected, based on a clean filter bed.
- Dimensions are estimates only. Actual dimensions may vary based on job-site space limits and piping layout. Allow 24" head room for media loading.
- Shipping weight are estimates only. Weight includes media and support gravel, which are to be added to the tanks after installation by end user.

Please contact us at: